

## Rivoirs, poussoirs et tasseaux pour potences à river 15285

Ils conviennent également à d'autres potences à river, dont les potences STAR.

Tige: Ø 4.7 mm / longueur 86 mm









## Punzen, Presstempel und Ambossen für Triebnietmaschinen 15285







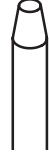

Sie eignen sich auch für andere Triebnietmaschinen, Dazu gehören auch die STAR-Triebnietmaschinen.











Schaft: Ø 4,7 mm / Länge 86 mm















## 15285-...

SWISS MADE 

					
			mm	mm	g
Rivoir en acier argent, à centrer <i>Zentrierpunze aus Silberstahl</i>		<b>15285-001</b>	4.70		11
Rivoir en acier argent, à élargir les bras de balanciers <i>Punze aus Silberstahl, zum Verlängern der Pendelarme</i>		<b>15285-016</b>			11
Rivoir en acier argent, à allonger les bras de balanciers <i>Punze aus Silberstahl, zum Verlängern der Unruharme</i>		<b>15285-019</b>			11
Rivoir en acier argent, plat <i>Punze aus Silberstahl, flach</i>		<b>15285-023</b>	4.50		11
		<b>15285-024</b>	4.00		11
		<b>15285-025</b>	3.70		11
		<b>15285-026</b>	3.30		11
		<b>15285-027</b>	3.00		11
		<b>15285-028</b>	2.70		11
		<b>15285-029</b>	2.30		11
		<b>15285-030</b>	2.00		11
		<b>15285-031</b>	1.70		11
		<b>15285-032</b>	1.50		11
		<b>15285-033</b>	1.20		11
<b>15285-034</b>	1.00		11		
Rivoir en acier argent, rond <i>Punze aus Silberstahl, rund</i>		<b>15285-035</b>	4.50		11
		<b>15285-036</b>	4.00		11
		<b>15285-037</b>	3.70		11
		<b>15285-038</b>	3.30		11
		<b>15285-039</b>	3.00		11
		<b>15285-040</b>	2.70		11
		<b>15285-041</b>	2.30		11
		<b>15285-042</b>	2.00		11
		<b>15285-043</b>	1.70		11
		<b>15285-044</b>	1.50		11
		<b>15285-045</b>	1.20		11
		<b>15285-046</b>	1.00		11
		Rivoir en acier argent, percé, trous en croix tournés <i>Punze aus Silberstahl, gebohrt, gedrehtes Kreuzloch</i>		<b>15285-047</b>	2.80
<b>15285-048</b>	2.50			1.00	11
<b>15285-049</b>	2.20			0.80	11
<b>15285-050</b>	1.80			0.60	11
<b>15285-051</b>	1.50			0.50	11
<b>15285-052</b>	1.20			0.40	11

							
			mm	mm	g		
Rivoir en acier argent, percé, trous en croix rabattus <i>Punze aus Silberstahl, gebohrt, umgeklapptes Kreuzloch</i>		<b>15285-053</b>	2.80	1.20	11		
		<b>15285-054</b>	2.50	1.00	11		
		<b>15285-055</b>	2.20	0.80	11		
		<b>15285-056</b>	1.80	0.60	11		
		<b>15285-057</b>	1.50	0.50	11		
		<b>15285-058</b>	1.20	0.40	11		
Rivoir en acier argent, plat, percé <i>Punze aus Silberstahl, flach, gebohrt</i>		<b>15285-065</b>	4.50	2.20	11		
		<b>15285-066</b>	4.00	2.00	11		
		<b>15285-067</b>	3.70	1.70	11		
		<b>15285-068</b>	3.30	1.50	11		
		<b>15285-068A</b>	3.10	1.30	11		
		<b>15285-069</b>	3.00	1.20	11		
		<b>15285-069A</b>	2.85	1.10	11		
		<b>15285-070</b>	2.70	1.00	11		
		<b>15285-070A</b>	2.50	0.90	11		
		<b>15285-071</b>	2.30	0.80	11		
		<b>15285-072</b>	2.00	0.70	11		
		<b>15285-073</b>	1.70	0.60	11		
		<b>15285-074</b>	1.50	0.50	11		
<b>15285-075</b>	1.20	0.40	11				
<b>15285-076</b>	1.00	0.30	11				
Rivoir en acier argent, grandes moyennes, percé <i>Punze aus Silberstahl, Minutenrad, gebohrt</i>		<b>15285-077</b>	4.50	1.50	11		
		<b>15285-079</b>	4.50	1.20	11		
		<b>15285-081</b>	4.50	1.00	11		
		<b>15285-083</b>	4.50	0.80	11		
		<b>15285-084</b>	4.50	0.70	11		
		<b>15285-085</b>	4.50	0.60	11		
		Rivoir en acier argent, concave, percé <i>Punze aus Silberstahl, rund, gebohrt</i>		<b>15285-086</b>	3.50	1.20	11
				<b>15285-087</b>	3.20	1.10	11
<b>15285-088</b>	3.00			1.00	11		
<b>15285-089</b>	2.80			0.90	11		
<b>15285-090</b>	2.40			0.80	11		
<b>15285-091</b>	2.00			0.70	11		
<b>15285-092</b>	1.80			0.60	11		
<b>15285-093</b>	1.60			0.50	11		
<b>15285-094</b>	1.40			0.40	11		
Rivoir en acier argent, ellipse, percé <i>Punze aus Silberstahl, ellipse, gebohrt</i>				<b>15285-095</b>	4.00	1.50	11
		<b>15285-097</b>	2.50	1.10	11		

					
			mm	mm	g
Rivoir en acier argent, rond, percé <i>Punze aus Silberstahl, rund, gebohrt</i>		15285-099	4.50	2.20	11
		15285-100	4.00	2.00	11
		15285-101	3.70	1.70	11
		15285-102	3.30	1.50	11
		15285-102A	3.10	1.30	11
		15285-103	3.00	1.20	11
		15285-103A	2.85	1.10	11
		15285-104	2.70	1.00	11
		15285-104A	2.50	0.90	11
		15285-105	2.30	0.80	11
		15285-106	2.00	0.70	11
		15285-107	1.70	0.60	11
		15285-108	1.50	0.50	11
15285-109	1.20	0.40	11		
15285-110	1.00	0.30	11		
Rivoir en acier argent, à chasser les vis et les tiges cassées <i>Punze aus Silberstahl, zum Austreiben von abgebrochenen Schrauben und Stäben</i>		15285-111	1.50		11
		15285-112	1.20		11
		15285-113	1.00		11
		15285-114	0.90		11
		15285-115	0.80		11
		15285-116	0.70		11
		15285-117	0.60		11
		15285-118	0.50		11
		15285-118A	0.45		11
		Rivoir en acier argent, concave et percé avec fraisure <i>Punze aus Silberstahl, ausgehöhlt und gebohrt mit Ausfräsung</i>		15285-119	3.50
15285-120	3.20			1.10	11
15285-121	3.00			1.00	11
15285-123	2.40			0.80	11
15285-125	1.80			0.60	11
15285-126	1.40			0.40	11
Rivoir en acier argent, pointu, percé <i>Punze aus Silberstahl, spitz und gebohrt</i>		15285-127	2.30	1.90	11
		15285-128	2.10	1.70	11
		15285-129	1.90	1.50	11
		15285-130	1.60	1.20	11
		15285-130A	1.50	1.10	11
		15285-131	1.40	1.00	11
		15285-131A	1.30	0.90	11
		15285-132	1.20	0.80	11
15285-132A	1.10	0.70	11		
Rivoir en acier argent, triangulaire <i>Punze aus Silberstahl, dreieckig</i>		15285-133	3.20		11
		15285-134	2.20		11
		15285-135	1.20		11
Rivoir en acier argent, plat, percé, fendu en X <i>Punze aus Silberstahl, flach, gebohrt, X-förmig geschlitzt</i>		15285-136	3.00	1.20	11
Rivoir en laiton, plat <i>Punze aus Messing, flach</i>		15285-139	4.00		12
		15285-140	3.00		12
		15285-141	1.70		12

					
			mm	mm	g
Rivoir en laiton, plat, percé <i>Punze aus Messing, flach, gebohrt</i>		15285-142	3.00	1.20	12
		15285-143	2.00	0.70	12
		15285-144	1.20	0.40	12
Poussoir en acier argent, plat, percé <i>Presstempel aus Silberstahl, flach, gebohrt</i>		15285-145	0.65	0.10	11
		15285-146	0.75	0.20	11
		15285-147	0.85	0.30	11
		15285-148	0.95	0.45	11
		15285-149	1.05	0.50	11
		15285-150	1.15	0.50	11
		15285-151	1.25	0.60	11
		15285-152	1.45	0.70	11
		15285-153	1.75	0.80	11
		15285-154	1.95	1.00	11
		15285-155	2.55	1.20	11
		15285-156	2.95	1.50	11
		Tasseau en acier trempé, plat <i>Amboss aus gehärtetem Stahl, flach</i>		15285-T01	9.00
15285-T02	4.50				3
15285-T03	3.50				2
15285-T04	2.50				2
15285-T05	1.00				2
Tasseau en acier trempé, plat, percé <i>Amboss aus gehärtetem Stahl, flach, gebohrt</i>		15285-T06	6.00	2.00	2
		15285-T07	4.70	1.50	2
		15285-T08	3.50	1.00	2
		15285-T09	2.50	0.70	2
15285-T10	2.00	0.40	2		
Tasseau en acier trempé, ellipse percé <i>Amboss aus gehärtetem Stahl, ellipse, gebohrt</i>		15285-T11	4.70	1.25	3
		15285-T12	3.50	1.00	2
Tasseau en acier trempé, bombé <i>Amboss aus gehärtetem Stahl, gewölbt</i>		15285-T13	4.50		3
		15285-T14	3.50		2
		15285-T15	2.50		2
		15285-T16	1.50		1
Tasseau en acier trempé, concave, percé <i>Amboss aus gehärtetem Stahl, vertieft, ausgehöhlt, gebohrt</i>		15285-T17	9.00	2.00	5
		15285-T18	6.00	1.50	4
		15285-T19	4.70	2.00	3
Tasseau en acier trempé, creusé <i>Amboss aus gehärtetem Stahl, vertieft</i>		15285-T20	4.00	3.50	2
		15285-T21	3.00	2.50	2
		15285-T22	2.50	2.00	2
15285-T23	2.00	1.50	2		
Tasseau en laiton, plat, percé <i>Amboss aus Messing, flach, gebohrt</i>		15285-T24	9.00	2.00	5
Tasseau en acier trempé, chasse-vis <i>Amboss aus gehärtetem Stahl, zum Ausschlagen von Schrauben</i>		15285-T25	1.50		2
Tasseau en acier trempé, chasse-vis, percé <i>Amboss aus gehärtetem Stahl, zum Ausschlagen von Schrauben, gebohrt</i>		15285-T26	3.00	1.00	2
		15285-T27	4.00	1.80	3
		15285-T28	6.00	3.00	4